

SHURE®

LEGENDARY
PERFORMANCE™

Wireless Systems

PGW | PGX | SLX® | ULX | UHF-R

PGX WIRELESS SYSTEMS

The Sound Choice



PGX Wireless Systems offer renowned Shure sound at an affordable price. Ten systems to choose from allow a tailored fit for different needs. Professional wireless technology – Ready to rock at the touch of a button.

Uncompromised Sound

- Wide variety of renowned Shure microphone capsules like the PG58, SM58®, SM86, Beta 58A and the Beta 87A
- Patented Shure Audio Reference Companding employs, unlike conventional wireless technology, a level dependent microphone circuitry

Ease-of-Use, Hassle-free Setup

- Auto Frequency Selection quickly locates the clearest channel
- Auto Transmitter Set-up synchronizes transmitter with receiver frequency at the touch of a button
- Up to 8 compatible systems per frequency range
- 1/4" and XLR audio outputs

Absolute Reliable Wireless Performance

- Microprocessor-controlled Predictive Diversity Technology automatically detects and prevents dropouts before they occur
- Tone Key to avoid power-switching noises and RF disturbances
- Frequency and power lockouts on receiver and transmitter
- Two "AA" batteries (included) provide over 8 hours of continuous use
- Up to 100 m (~ 300 ft.) operating range
- Optional rack-hardware available

Typical Shure Ruggedness

- Durable chassis built to Shure's high quality standards
- Robust carrying case

APPLICATIONS

Seminars

Churches

Music Clubs

Small Theatres

PRODUCT HIGHLIGHTS

Frequency Scan & Sync

Audio Reference
Companding

Microprocessor-
controlled Predictive
Diversity Technology

Wide variety of
renowned Shure micro-
phone capsules

System Specifications

Operating range	100 m (300 ft.) under typical conditions, depending on the transmitter type. <i>Note: actual range depends on RF signal absorption, reflection and interference.</i>
Audio frequency response	45 Hz – 15 kHz (± 2 dB)
Total harmonic distortion	< 0.5%, typical (ref. ± 38 kHz deviation, 1 kHz tone)
Dynamic range (A-weighted)	> 100 dB
Operating temperature range	-18°C (0°F) to +50°C (+122°F). <i>Note: battery characteristics may limit this range.</i>
Transmitter Audio Polarity	Positive pressure on microphone diaphragm (or positive voltage applied to tip of WA302 phone plug) produces positive voltage on pin 2 (with respect to pin 3) of low impedance output and the tip of the high impedance 1/4 inch output.

Frequency Range and Transmitter Output Level

Band	Range	PGX1 / PGX2
H6	524 – 542 MHz	≤ 30 mW
J6	572 – 590 MHz	≤ 30 mW
L5	644 – 662 MHz	≤ 30 mW
P6	702 – 720 MHz	≤ 30 mW
R1	800 – 820 MHz	≤ 20 mW
T1	846 – 865 MHz	≤ 10 mW

NOTE: This radio apparatus may be capable of operating on some frequencies not authorized in your region. Please contact your national authority to obtain information on authorized frequencies and output power levels for wireless microphone products in your region.

Receiver Block Diagram

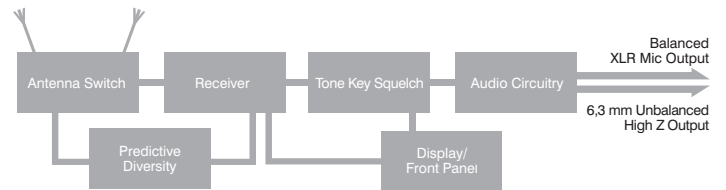

Optional Accessories

URT	Rack Tray
-----	-----------

PGX4 Wireless Receiver

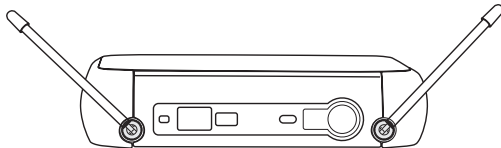

PGX4 Receiver Front

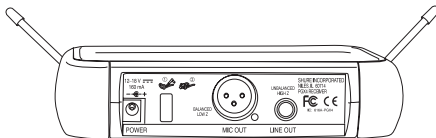

PGX4 Receiver Rear

Architectural Specifications

PGX4: The wireless receiver shall be a microprocessor-controlled diversity system including a tone key (32.768 kHz) to provide improved operation reliability and prevent switching noises. Preprogrammed groups with up to 8 compatible channels. An open frequency shall be selected automatically and synchronized with the transmitter via an infrared signal. It shall provide a RF-reception LED, LED showing frequency group and channel. The wireless receiver shall have a tone key squelch, XLR and 1/4" jack audio output as well as the possibility to lock the frequency.

Audio frequency response	45 Hz – 15 kHz (± 2 dB)
Dynamic range	> 100 dB(A)
System distortion (at 1 kHz; ± 38 kHz modulation)	< 0.5%
Audio output level (ref. ± 38 kHz deviation, 1 kHz tone)	XLR (into 600 Ω load): -19 dBV 1/4" connector (into 3000 Ω load): -5 dBV
Output impedance	XLR: 200 Ω 1/4": 1 k Ω
Sensitivity	-105 dBm for 12 dB SINAD, typical
Image rejection	> 70 dB, typical
RF carrier frequency	524 – 865 MHz (refer to the frequency supplement supplied with the system)
Power	12 – 18 Vdc at 150 mA, supplied by external power supply
Housing	Molded ABS
Dimensions (H x W x D)	40 mm x 181 mm x 104 mm
Weight	327 g

SHURE[®]
LEGENDARY
PERFORMANCE™

www.shure.com

Wireless Systems | PGX | 2

PGX1 Bodypack Transmitter

Architectural Specifications

PGX1: The wireless bodypack shall be a professional transmitter for audio signals with preprogrammed groups with up to 8 compatible channels. An infrared signal shall be used to synchronize the frequency between transmitter and receiver. The transmitter shall send a tone key (32.768 kHz) to provide improved operation reliability and prevent switching noises. The audio signal should be mutable. The transmitter shall have a 3-position input attenuator (mic, 0, -10 dB), a LED showing low battery and mute. 4-pin mini-connector (TA4M). Frequency locking capability shall be included. 2 "AA" alkaline batteries and softcase shall be included.

Product Specifications

Audio input level	-10 dBV max. at mic position +10 dBV max. at 0 dB gain position
Carrier frequency	524 – 865 MHz (available frequencies depend on applicable country regulations)
RF output level	10 – 30 mW (dependent on frequency version)
Battery life	> 8 hours with 2 "AA" size alkaline or rechargeable batteries
Housing	Molded ABS case
Dimensions (H x W x D)	108 mm x 64 mm x 19 mm
Weight	81 grams without batteries

System Versions

PG30	Headset
WL93	Lavalier Mic
WL185	Lavalier Mic
WB98H/C	Clip-On Instrument Mic
WA302	Instrument Cable (1,4" to TA4F)

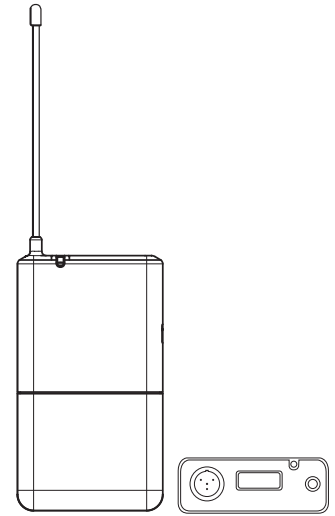

PGX1
Bodypack Transmitter

PGX2 Handheld Transmitter

Architectural Specifications

PGX2: The wireless microphone shall be a professional transmitter for audio signals with preprogrammed groups with up to 8 compatible channels. An infrared signal shall be used to synchronize the frequency between transmitter and receiver. The transmitter shall send a tone key (32.768 kHz) to provide improved operation reliability and prevent switching noises. The capsule shall be mutable. It shall have an input attenuator switch (0, -10 dB), a LED showing mute and battery strength status. Frequency capability shall be included. 2 "AA" alkaline batteries, mic clamp and softcase shall be included.

Product Specifications

Audio input level	+2 dBV max. at -10 dB gain position
Carrier frequency	524 – 865 MHz (available frequencies depend on applicable country regulations)
RF output level	10 – 30 mW (dependent on frequency version)
Battery life	> 8 hours with 2 "AA" size alkaline or rechargeable batteries
Housing	Molded ABS handle and battery cup
Overall dimensions (L x Ø)	PGX2/PG58: 238 x 51 mm PGX2/SM58: 254 x 51 mm PGX2/SM86: 243 x 51 mm PGX2/Beta58: 238 x 51 mm PGX2/Beta87A: 243 x 51 mm
Weight	290 grams (depends on mic capsule)

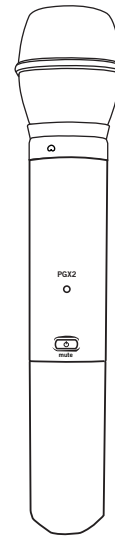

PGX2
Handheld Transmitter

Microphone Options

PGX2/PG58	Dynamic capsule, cardioid handheld mic
PGX2/SM58	Dynamic capsule, cardioid handheld mic
PGX2/SM86	Condenser capsule, cardioid handheld mic
PGX2/Beta58A	Dynamic capsule, supercardioid handheld mic
PGX2/Beta87A	Condenser capsule, supercardioid handheld mic

SHURE[®]
LEGENDARY
PERFORMANCE™

Europe, Middle East, Africa:

Shure Europe GmbH
Wannenackerstr. 28
74078 Heilbronn
Germany

Phone: +49 (0) 7131-7214-0
Fax: +49 (0) 7131-7214-14
Email: info@shure.de
www.shure.com

United Kingdom, Ireland:

Shure Distribution UK
Unit 2 The I O Centre
Lea Road
Waltham Abbey EN9 1AS
United Kingdom

Phone: +44 (0) 1992 703058
Fax: +44 (0) 1992 703057
Email: info@shuredistribution.co.uk
www.shure.co.uk

www.shure.com

© 2010 Shure Europe GmbH

05/2010

Whilst every effort has been made to ensure that the information in this document is correct, we accept no liability in respect of errors or omissions. All specifications within this document are subject to change without notice.